

21-RH1500

Original Instructions

GENERAL WARNINGS & DISPOSAL



To reduce the risk of injury, the user must read the instruction manual.



This symbol is used throughout this manual to warn the user about potential risks. Please read & understand these sections before using the device.



Personal Protective Equipment (P.P.E.), such as ear defenders, eye protection, safety gloves and a dust mask, must be worn during the operation of the device.



The device must not be exposed to rain or immersed in water.



Do not allow any part of the device to come into contact with flames, or to catch fire.



This product has been marked with a symbol relating to removing electric and electronic waste. The product should not be discarded with household waste but must be returned to a collection system which conforms to the European Directive 2012/19/EU. It will then be recycled or dismantled in order to reduce the impact on the environment. Electric and electronic equipment can be hazardous for the environment and for human health since they contain hazardous substances.

The month and year of manufacture can be found within the product serial number e.g. MMYPPPAXXXXX. Where production month (MM) and production year (YY) are included.



Contents

| | |
|--|----|
| GENERAL POWER TOOL SAFETY WARNINGS | 4 |
| 1. Work area safety | 4 |
| 2. Electrical safety | 4 |
| 3. Personal safety | 4 |
| 4. Power tool use and care | 5 |
| 5. Service | 5 |
| TOOL SPECIFIC SAFETY WARNINGS | 6 |
| Safety instructions for all operations | 6 |
| Safety instructions when using drill bits | 6 |
| Safety instructions when using hammer mode | 6 |
| COMPONENT LIST | 8 |
| TECHNICAL DATA | 9 |
| NOISE INFORMATION | 9 |
| VIBRATION INFORMATION | 10 |
| OPERATING INSTRUCTIONS | 11 |
| Intended Use | 11 |
| Attaching the Side Handle | 11 |
| Replacing Bits | 11 |
| On/Off trigger | 11 |
| Variable Speed | 11 |
| Rotation Selector | 12 |
| Maintenance | 13 |
| Transport and Storage | 13 |
| WARRANTY STATEMENT | 14 |
| Terms & Conditions | 14 |
| EU/UK DECLARATION OF CONFORMITY | 16 |



GENERAL POWER TOOL SAFETY WARNINGS

WARNING!

Read all safety warnings, instructions and specifications provided with this power tool. Failure to follow all instructions listed below may result in electric shock, fire and/or serious injury. **Save all warnings and instructions for future reference.**

The term “power tool” in the warnings refers to your mains operated (corded) power tool or battery operated (cordless) power tool.

1. Work area safety

> Keep work area clean and well lit.

Cluttered or dark areas invite accidents.

> Do not operate power tools in explosive atmospheres, such as in the presence of flammable liquids, gases or dust. Power tools create sparks which may ignite the dust or fumes.

> Keep children and bystanders away while operating a power tool. Distractions can cause you to lose control.

2. Electrical safety

> Power tool plugs must match the outlet. Never modify the plug in any way. Do not use any adapter plugs with earthed (grounded) power tools. Unmodified plugs and matching outlets will reduce risk of electric shock.

> Avoid body contact with earthed or grounded surfaces, such as pipes, radiators, ranges and refrigerators. There is an increased risk of electric shock if your body is earthed or grounded.

> Do not expose power tools to rain or wet conditions. Water entering a power tool will increase the risk of electric shock.

> Do not abuse the cord. Never use the cord for carrying, pulling or unplugging the power tool. Keep the cord away from heat, oil, sharp edges or moving parts.

Damaged or entangled cords increase the risk of electric shock.

> When operating a power tool outdoors, use an extension cord suitable for outdoor use. Use of a cord suitable for outdoor use reduces the risk of electric shock.

> If operating a power tool in a damp location is unavoidable, use a residual current device (RCD) protected supply. Use of an RCD reduces the risk of electric shock.

3. Personal safety

> Stay alert, watch what you are doing and use common sense when operating a power tool. Do not use a power tool while you are tired or under the influence of drugs, alcohol or medication. A moment of inattention while operating power tools may result in serious personal injury.

> Use personal protective equipment. Always wear eye protection. Protective equipment such as a dust mask, non-skid safety shoes, hard hat or hearing protection used for appropriate conditions will reduce personal injuries.

> Prevent unintentional starting. Ensure the switch is in the off position before connecting to power source and/or battery pack, picking up or carrying the tool. Carrying power tools with your finger on the switch or energising power tools that have the switch on invites accidents.

- **Remove any adjusting key or wrench before turning the power tool on.** A wrench or a key left attached to a rotating part of the power tool may result in personal injury.
 - **Do not overreach. Keep proper footing and balance at all times.** This enables better control of the power tool in unexpected situations.
 - **Dress properly. Do not wear loose clothing or jewellery. Keep your hair and clothing away from moving parts.** Loose clothes, jewellery or long hair can be caught in moving parts.
 - **If devices are provided for the connection of dust extraction and collection facilities, ensure these are connected and properly used.** Use of dust collection can reduce dust-related hazards.
 - **Do not let familiarity gained from frequent use of tools allow you to become complacent and ignore tool safety principles.** A careless action can cause severe injury within a fraction of a second.
- 4. Power tool use and care**
- **Do not force the power tool. Use the correct power tool for your application.** The correct power tool will do the job better and safer at the rate for which it was designed.
 - **Do not use the power tool if the switch does not turn it on and off.** Any power tool that cannot be controlled with the switch is dangerous and must be repaired.
 - **Disconnect the plug from the power source and/or remove the battery pack, if detachable, from the power tool before making any adjustments, changing accessories, or storing power tools.** Such preventive safety measures reduce the risk of starting the power tool accidentally.
 - **Store idle power tools out of the reach of children and do not allow persons unfamiliar with the power tool or these instructions to operate the power tool.** Power tools are dangerous in the hands of untrained users.
 - **Maintain power tools and accessories. Check for misalignment or binding of moving parts, breakage of parts and any other condition that may affect the power tool's operation. If damaged, have the power tool repaired before use.** Many accidents are caused by poorly maintained power tools.
 - **Keep cutting tools sharp and clean.** Properly maintained cutting tools with sharp cutting edges are less likely to bind and are easier to control.
 - **Use the power tool, accessories and tool bits etc. in accordance with these instructions, taking into account the working conditions and the work to be performed.** Use of the power tool for operations different from those intended could result in a hazardous situation.
 - **Keep handles and grasping surfaces dry, clean and free from oil and grease.** Slippery handles and grasping surfaces do not allow for safe handling and control of the tool in unexpected situations.
- 5. Service**
- **Have your power tool serviced by a qualified repair person using only identical replacement parts.** This will ensure that the safety of the power tool is maintained.



TOOL SPECIFIC SAFETY WARNINGS

1. Safety instructions for all operations

- › **Wear ear protectors when impact drilling.** Exposure to noise can cause hearing loss.
- › **Use the auxiliary handle(s).** Loss of control can cause personal injury.
- › **Hold the power tool by insulated gripping surfaces, when performing an operation where the cutting accessory or fasteners may contact hidden wiring.** Cutting accessory contacting a “live” wire may make exposed metal parts of the power tool “live” and could give the operator an electric shock.

2. Safety instructions when using drill bits

- › **Never operate at higher speed than the maximum speed rating of the drill bit.** At higher speeds, the bit is likely to bend if allowed to rotate freely without contacting the workpiece, resulting in personal injury.
- › **Use a detector to locate lines in walls with concealed electric, water or gas lines. Avoid touching live components or conductors.** Inadvertant contact with hidden items may cause serious injury or damage to the tool.
- › **Always start drilling at low speed and with the bit tip in contact with the workpiece.** At higher speeds, the bit is likely to bend if allowed to rotate freely without contacting the workpiece, resulting in personal injury.

- › **Apply pressure only in direct line with the bit and do not apply excessive pressure.** Bits can bend causing breakage or loss of control, resulting in personal injury.

3. Safety instructions when using hammer mode

- › **Keep exposure to vibrations as short as possible. When carrying out work, always hold the hammer with both hands and ensure that you have a stable standing position.** Vibrations can injure the nerves in hands & arms.



COMPONENT LIST

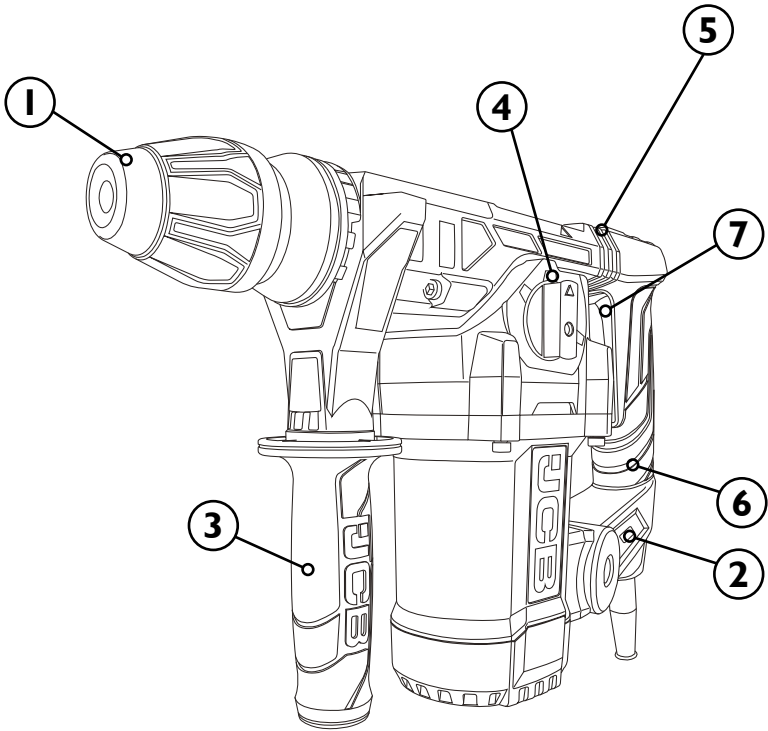

- 1. SDS DRILL CHUCK
- 2. VARIABLE SPEED SWITCH
- 3. SIDE HANDLE
- 4. MODE SELECTOR
- 5. ANTI-VIBRATION SYSTEM
- 6. SOFT GRIP
- 7. ON/OFF TRIGGER



TECHNICAL DATA

| | | |
|---------------------------------|----------------|----------------|
| Input Voltage | | 230-240V~ 50Hz |
| Power | | 1500W |
| No Load Speed | | 0-920/min |
| Clutch Position | | 4 Modes |
| Hammer Impact Rate | | 0 - 4230 bpm |
| Impact Force | | 6J |
| Chuck Type | | SDS Plus |
| Max. Drilling Capability | Wood | 42 mm |
| | Steel | 13 mm |
| | Masonry | 32 mm |
| Product Weight | | 5.3 kg |

NOISE INFORMATION

| | |
|---|------------|
| A-Weighted Sound Pressure (LpA) | 88.0dB (A) |
| A-Weighted Sound Level (LwA) | 99.0dB (A) |
| K_{pA} & K_{wA} | 3 dB (A) |
| Wear ear protection when sound pressure is over 80 dB(A) | |



VIBRATION INFORMATION

Vibration total values (triax vector sum) determined according to EN 60745-1 and EN 60745-2-6

| | | |
|--------------------------------------|---------------------------|-------------------------|
| Vibration Emission Value (ah) | a_{h,HD} | 11.692 m/s ² |
| | a_{h,CHeq} | 14.245 m/s ² |
| Uncertainty (K) | | 1.5 m/s ² |

WARNING!

The vibration emission value of the power tool is tested under EN 60745-1 and EN 60745-2-6, and can vary during operation depending on the following usage conditions:

- How the tool is used and the materials being cut or drilled.
- The tool being in good condition and well maintained.
- Using the correct accessory for the tool and ensuring it is sharp and in good condition.
- The tightness of the grip on the handles and if any anti-vibration accessories are used.
- The tool being used as intended by its design and these instructions.
- The declared vibration total value may also be used in a preliminary assessment of exposure.

THIS TOOL MAY CAUSE HAND-ARM VIBRATION SYNDROME IF USAGE IS NOT ADEQUATELY MANAGED.

WARNING!

To be accurate, an estimation of exposure level in the actual conditions of use should also take account of all parts of the operating cycle. These include times when the tool is switched off and when it is running idle but not actually doing work. This may significantly reduce the total exposure level over the working period, helping to minimize your vibration exposure risk.

- ALWAYS use sharp and undamaged bits, chisels, drills and blades.
- Maintain this tool in accordance with these instructions and keep well lubricated (where appropriate).
- If the tool is to be used regularly then invest in anti-vibration accessories.
- Avoid using tools in temperatures of 10°C or less.
- Plan your work schedule to spread any high vibration tool use across a number of days.

OPERATING INSTRUCTIONS

Intended Use

This rotary hammer drill is intended for drilling in stone, wood, metal, ceramics and plastics, percussion drilling in brickwork, concrete and stone and percussive chiselling in masonry and plaster.

The tool must not be modified or used for any other purposes than the ones described in these instructions.

Attaching the Side Handle

- Push the side handle over the drill chuck and screw into place.
- The side handle can be fitted to suit both right-handed and left-handed users.

Replacing Bits



WARNING!

Tool accessories can be very sharp and can become very hot during use - risk of personal injury.

NOTE

The device is equipped with a SDS- plus attachment system.

- Check that the tool accessory is properly positioned & locked into the tool holder.

NOTE

Check that the accessory is straight, centred and not askew. If the accessory is not properly positioned it could fly out when starting the tool.

On/Off Trigger (7)

- Press the on/off trigger to start the tool.

The tool has variable speed, and a lock button for constant use.

Variable Speed Switch (2)

- Press the on/off trigger to increase the speed.
- Adjust the variable speed switch to the appropriate speed.
- Release the on/off trigger to stop the tool.

- Place the tool on a stable surface, for example a work bench.
- Clean tools and grease with a thin layer of machine grease before fitting.
- Pull back fastening sleeve and hold.
- Push and rotate the dust-free tool into the tool holder as far as it will go. The tool will lock automatically.



Mode Selector (4)

Drilling Mode

WARNING!

Use the correct specification of drill bit for the material and power tool you are working with. Incorrect selection may cause damage to the tool, workpiece or bit.

NOTE

Check that the drill is correctly inserted into the chuck before starting the tool.

- › If loose, clamp the work piece. The work piece should lie flat on a workbench, and/or be securely fixed.
- › Mark out the position of the hole by suitable means.
- › Use a suitable drill for your material.
- › Ensure all drills are sharp.
- › When drilling in metal, make sure that the drill is always sufficiently cooled with a non-flammable liquid.
- › Start drilling at low speed.
- › If you are drilling large holes, pre drill with a small drill and then finish off with a large drill.
- › Do not force the tool - do not press too hard on the drill.

Hammer Drilling Mode

- › Set the mode selector switch to this mode to enable the hammer function alongside drilling. The hammer drilling function allows more effective drilling into hard, brittle materials such as concrete, brick and stone.

Percussion Chiselling Mode

- › Set the mode selector switch to this mode to enable the percussive hammer function without rotating the tool. The percussion chiselling function allows fast removal of hard, brittle materials such as concrete, brick and stone.

Chisel Adjustment Mode

- › Chisel adjustment mode unlocks the chuck, allowing the user to rotate the attached tool to the required position.

Maintenance

WARNING!

Switch off the tool and disconnect the power (remove battery/unplug) before cleaning and maintenance – risk of electric shock and accidental start.

- Wipe the tool with a dry or damp cloth. Do not use a wet cloth. Do not use detergent that contains solvent or corrosive, abrasive additives – risk of damaging the surface.
 - Keep the ventilation openings open – risk of overheating.
 - Clear the tool vents and the accessory mount of dust and dirt after each use. Do not clean ventilation holes by inserting sharp objects in them, such as screwdrivers and other similar objects.
 - Stubborn contamination in areas hard to access can be removed with compressed air (max 3. bar).
 - Regularly check all fasteners, screws and bolts to make sure that they are tight. Tighten any loose screws immediately – serious injury could occur.
 - If power cord becomes damaged and replacement is necessary, this must be carried out by an authorised warranty agent.
- Store the tool in a dry, frost-free, well ventilated place with a temperature of no more than 40°C and out of the reach of children.
 - Always Switch off the tool and disconnect it from the power supply (remove the battery/unplug the power cord) before transport.
 - Always carry the tool using the purpose-designed handle.
 - Always carry the tool using the purpose-designed handle.
 - Ensure that the tool is not at risk of tipping over or exposed to vibration and shocks during transport, especially if the tool will be transported by car or other vehicle.

WARNING!

Never open the tool. The tool has no internal parts that the user can service or repair. Never try to repair the tool yourself. Take to an authorised service centre.

Transport and Storage

- If the tool shall remain unused for any length of time, it should be stored in the original packaging.



WARRANTY STATEMENT

JCB Power Tools are guaranteed against manufacturing defects for up to 3 years from date of purchase by simply registering your product online within 30 days. Proof of purchase required. This does not affect your statutory rights.

To register your JCB Power Tool, please visit: jcb-tools.com

Online registration is required within 30 days to receive a warranty certificate to activate your standard 3 year warranty. Registration is only available online via www.jcb-tools.com. You will need your original sales receipt, the model number and the serial number (if applicable) of your product. Kits comprising of two or more tools are excluded from single registration and must be registered individually for full warranty cover.

Upon successful registration, a warranty certificate will be available to download, print or save as a PDF document. The relevant warranty certificate together with the original sales receipt will be required in the event of any claim within the warranty period.

Should you choose not to register your product within 30 days of purchase, your statutory consumer rights will not be affected. You will need the original sales receipt as proof of purchase in the event of a warranty claim.

Warranty cover commences from the date of purchase on the retail sales receipt and is valid only for JCB Tools products purchased within the UK bearing the CE and UKCA mark and a visible serial number.

In the unlikely event your JCB Power Tool is subject to a manufacturing fault within the warranty period, JCB Tools may repair the product by replacing defective parts free of charge at our discretion. In the event parts are irreplaceable JCB Tools may replace your product free of charge. The original product will remain the property of JCB Tools in this situation.

The above repair or replacement of products will be undertaken providing that:

- The product has been subject to fair wear and tear only.
- The product has not been subject to accidental or cosmetic damage.

- The product has not been misused and has been used only in accordance with the instruction manual provided.
- The product has not been subject to overload or insufficient servicing and maintenance.
- The product has not been subject to any abnormal environmental conditions or inappropriate operating conditions.
- Repairs have not been attempted by an unauthorised person and no modifications have been made to the product.
- Repairs have not been undertaken using non-genuine spare parts.

JCB Power Tools used for Hire Fleets or as part of B2B and Service Contracts are not covered by these terms and conditions.

JCB Tools 3 Year Warranty excludes the following (where applicable):

- Components normally subject to wear such as carbon brushes.
- Batteries, Chucks and Chargers.
- Accessories and consumable items.
- Cases and tool storage products.

If your product develops a fault within 30 days of purchase, return it to the retailer where it was purchased together with your sales receipt. If a product develops a fault after 30 days a warranty claim must be submitted.

If you have a warranty claim please take your product, original sales receipt and if applicable, a copy of your extended warranty certificate to your place of purchase or nearest JCB Tools retailer.

If you wish to send your product to us directly, please send to JCB Tools, Unit 55, Romsey Industrial Estate, Greatbridge Road, Romsey, Hampshire, SO51 0HR, along with your original receipt and, if applicable, a copy of your extended warranty certificate. Delivery and repair charges may apply at our discretion should the warranty claim be invalid for any of the reasons illustrated above. In the event charges are not accepted the product will be retained by JCB Tools and remain the property of JCB Tools.

The information on both your sales receipt and your extended warranty certificate must match.

JCB TOOLS WILL NOT BE LIABLE FOR ANY INJURIES OR CONSEQUENTIAL DAMAGES RESULTING FROM USE OF THIS PRODUCT.



| EU DECLARATION OF CONFORMITY | | | | UK DECLARATION OF CONFORMITY |
|--|---|---|--|------------------------------|
| 1. | PRODUCT(S) COVERED BY THIS DECLARATION: | Product: UK Product Code No. EU Product Code No. Factory Reference No. | Corded Rotary Hammer Drill 1500W SDS Plus JCB-RH1500, 21-RH1500 JCB-RH1500-E Z1C-DS-32MB | Batch/PO No. |
| 2. | IDENTIFICATION DETAILS OF MANUFACTURER: | Name: Address: Country: | Yellow and Black Tools Ltd. (T/A: JCB Tools) Unit 55 Romsey Industrial Estate, Greatbridge Road Romsey, Hampshire SO51 0HR UK | |
| | AUTHORISED REPRESENTATIVE: | Name: Address: Country: | Authorised Representative Service 77 Camden Street Lower Dublin DO2 XE80 Ireland | |
| THIS DECLARATION OF CONFORMITY IS ISSUED UNDER THE SOLE RESPONSIBILITY OF THE MANUFACTURER | | | | |
| 4. | OBJECT OF THE DECLARATION: | Product: Function: | Corded Rotary Hammer Drill 1500W SDS Plus Drilling, Percussion Drilling and Percussion Chiselling. | |
| 5i. | THE OBJECT OF THE DECLARATION DESCRIBED IN POINT 4 IS IN CONFORMITY WITH THE RELEVANT UNION HARMONISATION LEGISLATION: | 2006/42/EC | The Machinery Directive | |
| | | 2014/30/EU | The Electromagnetic Compatibility Directive | |
| | | 2011/65/EU | The Restriction of Hazardous Substances Directive | |
| 5ii. | THE OBJECT OF THE DECLARATION DESCRIBED IN POINT 4 IS IN CONFORMITY WITH THE RELEVANT UK STATUTORY INSTRUMENTS: | 2008 No. 1597 | The Supply of Machinery (Safety) Regulations 2008 | |
| | | 2016 No. 1091 | The Electromagnetic Compatibility Regulations 2016 | |
| | | 2012 No. 3032 | The Restriction of the Use of Certain Hazardous Substances in Electrical and Electronic Equipment Regulations 2012 | |
| 6. | REFERENCES TO THE RELEVANT HARMONISED SAFETY STANDARDS USED OR REFERENCES TO THE OTHER TECHNICAL SPECIFICATIONS IN RELATION TO WHICH CONFORMITY IS DECLARED: | EN 60745-1:2009+A11 EN 60745-2-6:2010 EN 55014-1:2017 EN 55014-2:2015 EN 61000-3-2:2019 EN 61000-3-3:2013+A1 | Hand-held motor-operated electric tools. Safety. General requirements Hand-held motor-operated electric tools. Safety. Particular requirements for hammers Electromagnetic compatibility. Requirements for household appliances, electric tools and similar apparatus. Emission Electromagnetic compatibility. Requirements for household appliances, electric tools and similar apparatus. Immunity Electromagnetic compatibility (EMC). Limits. Limits for harmonic current emissions (equipment input current ≤ 16 A per phase) Electromagnetic compatibility (EMC). Limits. Limitation of voltage changes, voltage fluctuations and flicker in public low-voltage supply systems, for equipment with rated current ≤ 16 A per phase and not subject to conditional connection | |
| 7. | ADDITIONAL INFORMATION. THE TECHNICAL DOCUMENTATION FOR THE MACHINERY IS AVAILABLE FROM: | Name: Address: Country: | Authorised Representative Service 77 Camden Street Lower Dublin DO2 XE80 Ireland | |
| SIGNED FOR AND ON BEHALF OF: PLACE OF ISSUE: DATE OF ISSUE: NAME: FUNCTION: SIGNATURE: | | YELLOW AND BLACK TOOLS LTD. ROMSEY, UK. 25/06/2021 TIM BURGOWNE QA MANAGER | | |